

# INSTALLATION GUIDE

## ■ DIAGRAM for ECO Series

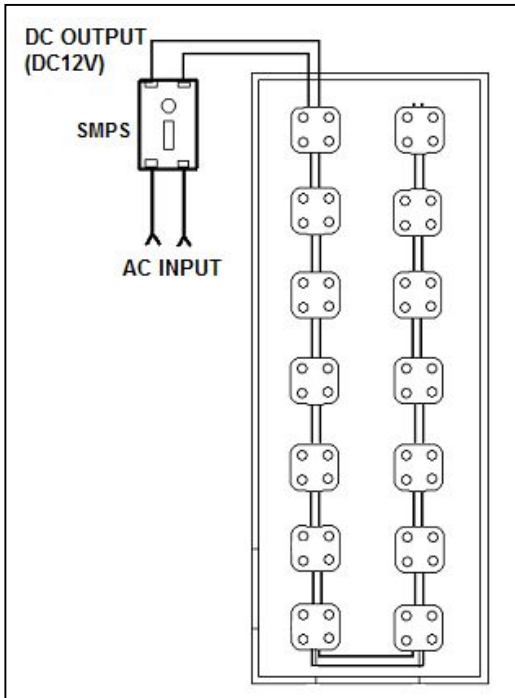

### 1. Maximum run

: 50 pcs in series / depends on SMPS in parallel

### 2. Maximum Usage of SMPS Capacity

= SMPS capacity \* 0.8 (80%)

ex) In case using 200W SMPS,  
 $200W * 0.8 = 160W$  for the best stability

Watts of LED Modules = Number of LEDs \* 0.24W

ex) In case 200pcs of ECO3S-W,  
 $200 * 3 * 0.24 = 144W$

### 3. Pitch between modules : See the last page

## ⚠ CAUTION

Any actions against following contents will cause serious issues such as malfunction, electric shock or burn.

1. Do not connect directly to AC 100V / 220V
2. Make sure that the wire connection of INPUT (AC 100V/ 220V) & OUTPUT (DC 12V) is not switched.
3. Make sure that its polarity (+, -) is connected right. (Red lined-cable : +, White cable : -)
4. Do not over the maximum connectable numbers of module. 50EA in series.
5. Do not cut wire or any kinds of wiring while modules are connected with live power source
6. Avoid installation under rain or high humidity for outdoor use.  
Installed LED Sign must be covered for outdoor use. Should be protected from rain and direct ray of the sun for a long term use. It can causes crack of LED lamps.  
For indoor use where possibly has human contacts must be covered too.
7. Do not use in the circumstance of over 70% humidity
8. Do not touch LED lamps with sharp objects
9. Make holes for water drain on the down side of channel letter for outdoor use.
10. Strand of modules must be capped with wire nut, compression tube or insulating tape to protect from electric leakage.

# INSTALLATION GUIDE

## ■ LED Channel Installation direction

### Tools & Supplies



Wire Stripper, Drill, Screw Driver, Tower, Wire nuts, Nippers, Insulating tape, Compression Tube, Connection cable to power, Bushing.

(Option: Silicon and Screws)

### Materials

- \* LED Modules : ECO Series Modules
- \* Channel Letter Height : 80~120mm
- \* Recommended cover materials :  
Light diffusion PC (Polycarbonate) or  
Acrylic exclusive for LED
- \* Recommended paint color inside channel letter  
: White color for better reflection of LED lights



1. Clean the moisture, dust and oil inside the channel letter and check if there is scratch or breakage.

Adhesive tape will be taken off easily in case products is mounted on dirty and uneven surfaces.

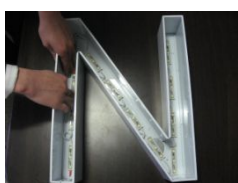

2. Using predetermined layout, place LED modules with adhesive tape on the backside of modules. Make sure that modules are firmly attached on the surface.



Do not press down directly on the top of LED lamp to avoid any damages.



3. Make holes using drill, one for wiring on the backside of channel letter, another one for water drain on downside. Use bushing to protect wires from an electric leakage.



4. To fix modules permanently, spread silicon on the side of modules

5. Do wire between LED modules and power supply(SMPS) minimizing the wire length. ( Above 5meter wiring, need consulting)

6. Cap all strand of modules using wire nut or compression tube, silicon for waterproofing.



7. Power on the power supply(SMPS) and do lighting test.

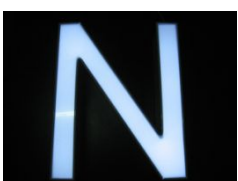

8. If lighting has no problem, cover the channel letter and check the exterior.

# INSTALLATION GUIDE

## LED Module Diagram

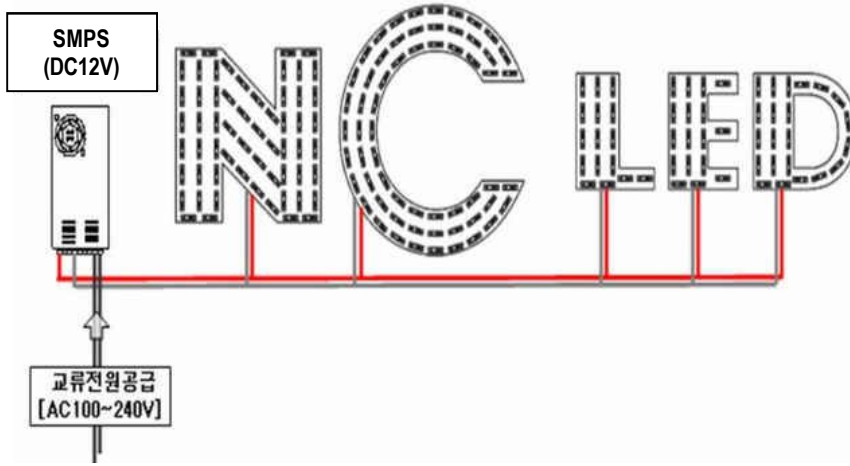

## LED Module Pitch

ECO 1

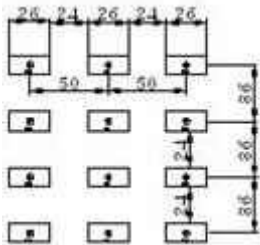

ECO 2S

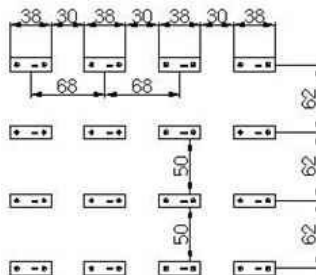

ECO 2

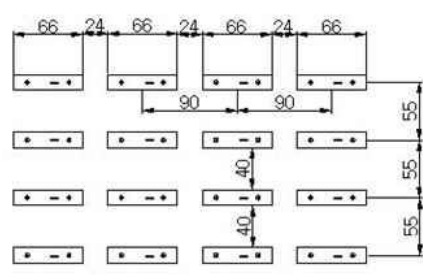

ECO 3S

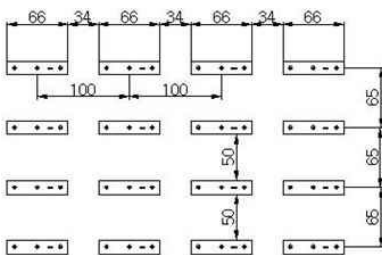

ECO 3

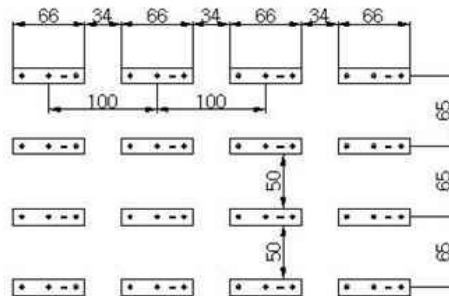

ECO 4

